

2. 设置正转、反转、停止

01 10 01 01 00 00 00 27 10 01 64 CRCH CRCL

English manual of smc01 controller

Physical button | LCD | Industrial controller **ZK-SMC01**

Single Axis Stepping Motor Controller

Pulse / direction control • Auto / manual • TTL serial communication



- ✓ Adjustable Delay
- ✓ Speed Regulation
- ✓ Angle Adjustment
- ✓ Adjusting Distance

Disclaimer:

For electronic module products, you need to have a certain electronic foundation and carefully read the product description before use; The product is not designed for medical, life-saving, life support and other purposes, and cannot be used in dangerous places such as coal mine and oil depot. We do not guarantee such responsibilities; The product profit is low, the user's operation ability and use occasions vary greatly, and any electronic equipment cannot be foolproof. The equipment owner shall make corresponding protective measures and risk management plan. The company shall not be liable for compensation for any personal or property loss directly or indirectly caused by the equipment.

1. Product introduction

This is a special operation control module for single shaft stepping motor.

A variety of fixed operation modes are built in the module, and users can quickly select the appropriate motion track. The distance / speed / delay / number of cycles can be saved and set after power down. It can run independently as a module, or it can be used together with other systems.

It can be used in general industrial control occasions, not in special industries such as medical treatment and fire protection or life-threatening fields.

2. Product parameters

Model: ZK-SMC01 stepper motor controller

Adaptive motor: stepping motor

Number of control axes: single axis

Motor signal: common cathode

Power supply range: DC 5-30V general

Instruction features: streamline and optimize multiple common instructions

Acceleration and deceleration control: Yes

Input reverse connection protection: Yes

Remote communication control: TTL serial port

Main functions of the system: automatic, manual, setting and serial port control

Speed range: 0.1 ~ 999 laps / min

Number of forward rotation pulses: 1-9999999 pulses

Number of reverse pulses: 1-9999999 pulses

Number of cycles: 1-9999

Forward rotation delay time: 0.0-999.9 seconds

Reverse delay time: 0.0-999.9 seconds

Subdivision selection range: 1-128 subdivision

Product service environment: - 5 °C - 60 °C (no condensation)

3. Product function

Product function

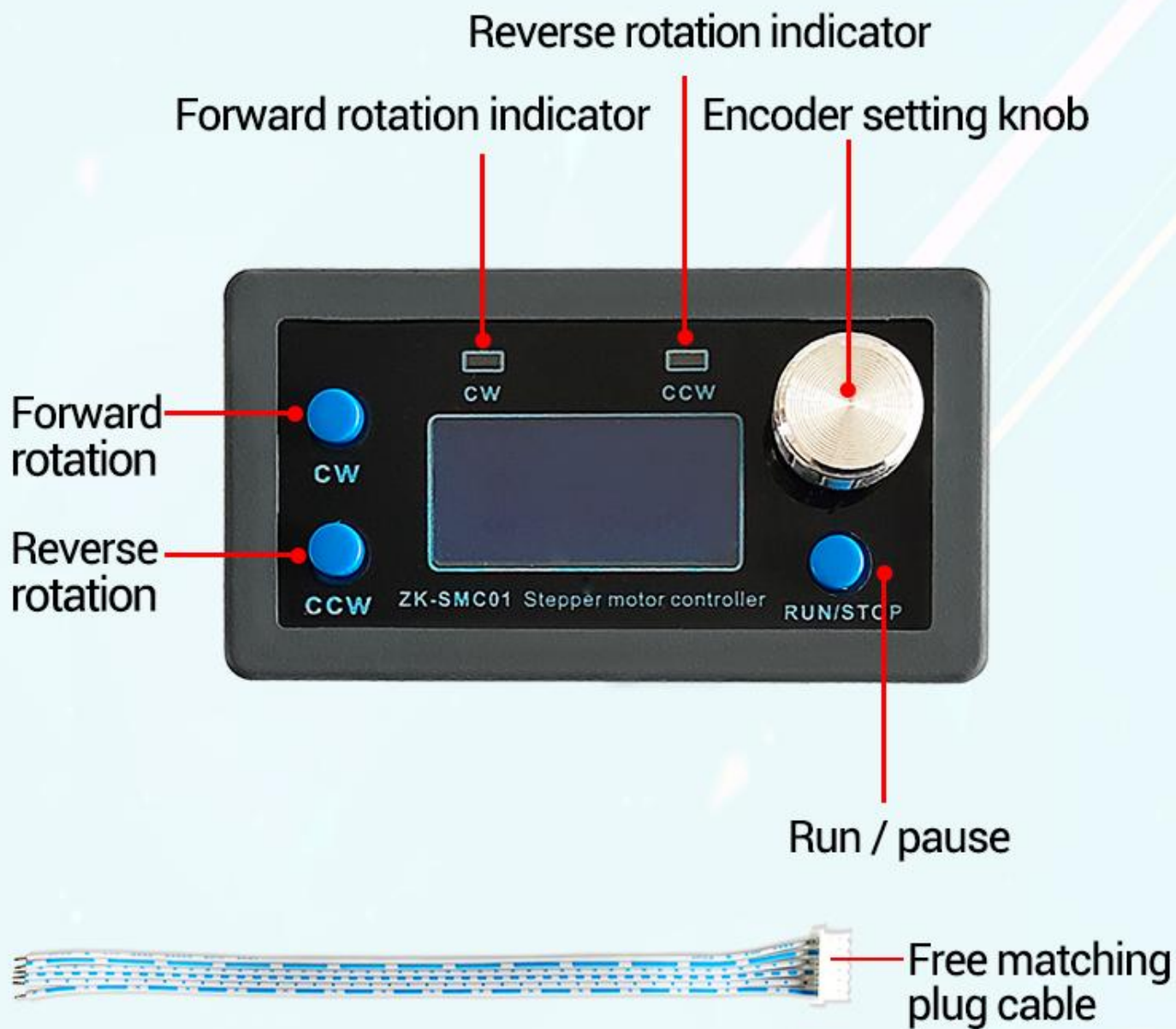

4. Product details

Product details

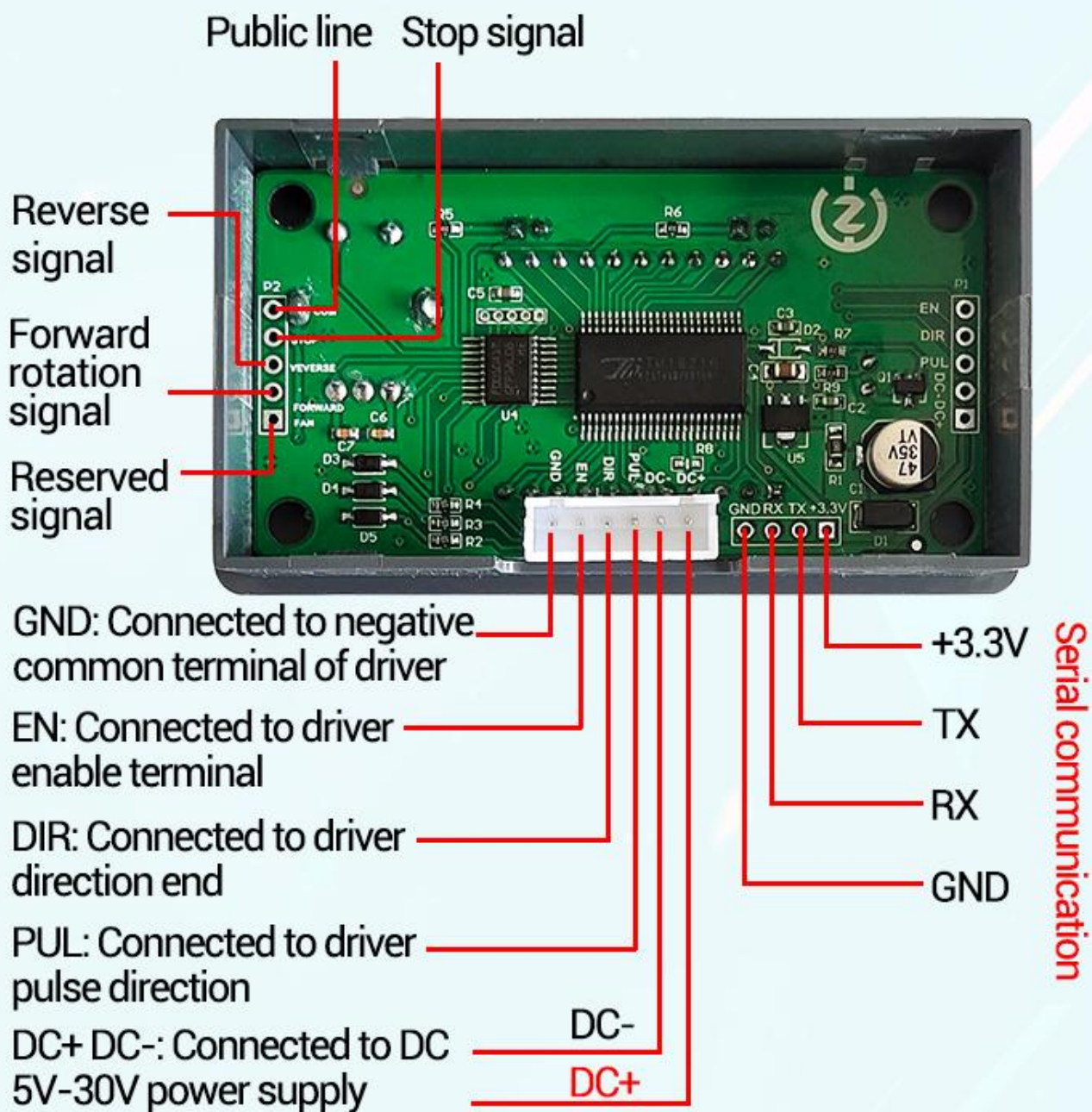

5. Product wiring

Product wiring

Control common drives in the market

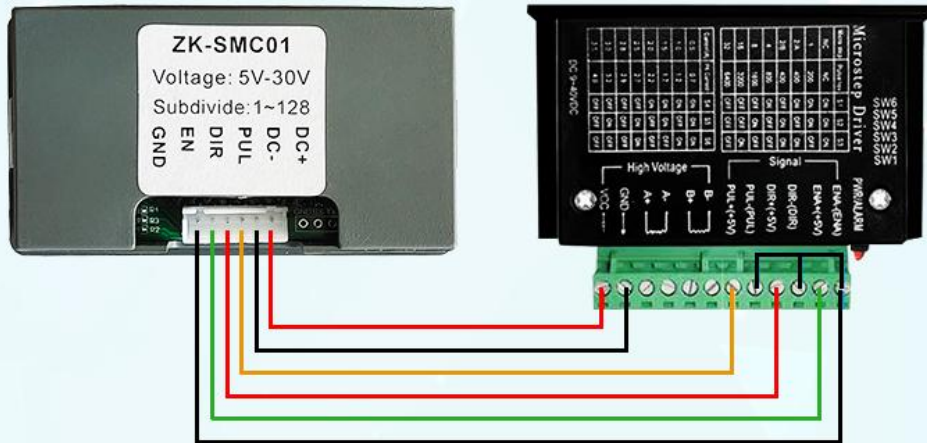

Control THB6128 stepper motor driver

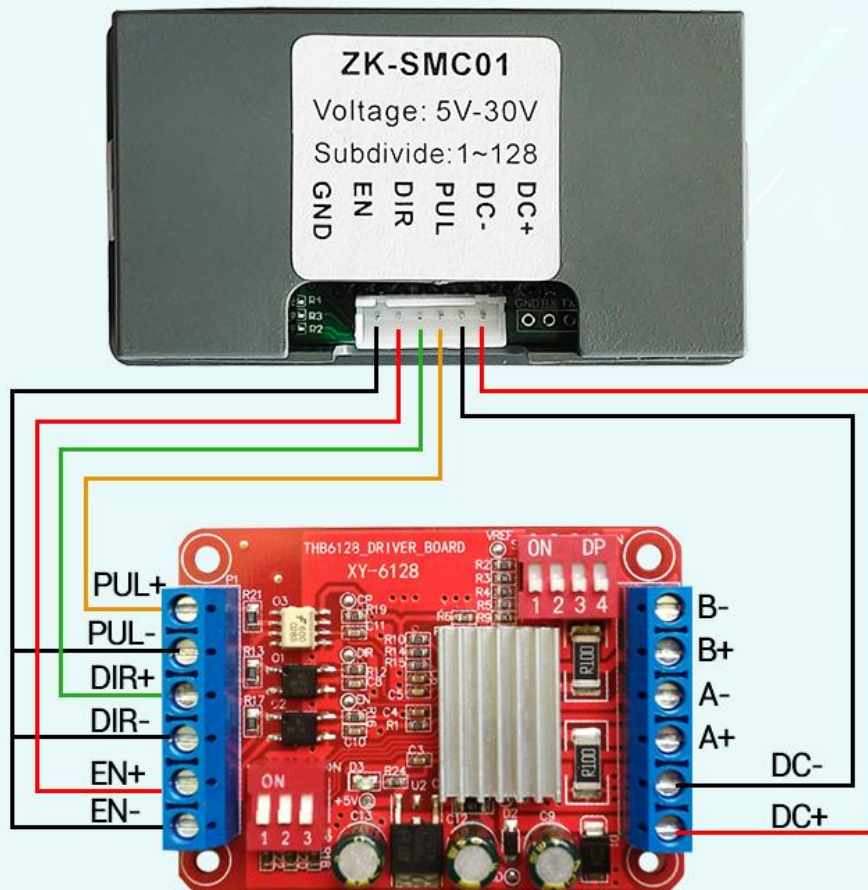

6. Interface function introduction and operation method

The controller is divided into two interfaces: operation + interface+[F] menu setting interface

Interface function



RUN INTERFACE

Used to display running information during work



MENU SETTING INTERFACE

In actual work, the parameters that need to be modified are all concentrated here.

Operating instructions

Operating instructions



Run stop exit

In the running interface, the rotary encoder adjusts the speed, CW button-forward rotation, CCW button-reverse rotation, RUN/STOP button-operation stops and exits. Long press the encoder to enter the menu settings.



In the menu setting interface, adjust the rotary encoder to change the parameter codes F-01~F-13. Long press the encoder, save the parameters and exit, enter the running interface.



Exit parameter setting

In the menu setting interface, short press the encoder to enter the F-XX corresponding menu parameter setting state, the parameter flashes, short press again to shift, rotate the encoder to adjust the parameters. Short press the RUN/STOP button to exit the parameter setting and return to the main menu number adjustment interface.

List of all [F] menu setting functions

Serial number	Function	Adjustable range	Defaults
F-01→?	Action flow mode selection(details below the table)	1-9	1
F-02	Number of forward rotation pulses Unit: number(the upper three bits are adjusted by rotary encoder shift, and the upper three bits display Hxxx, and the lower four bits display xxxx)	1 - 9999999	1600
F-03	Forward rotation speed Unit: Revolution / minute	0.1-999	10
F-04	Number of reverse pulses Unit: Number(the upper three bits are adjusted by rotary encoder shift, and the upper three bits display Hxxx, and the lower four bits display xxxx)	1 - 9999999	1600
F-05	Reversal speed Unit: circle (revolution)/min	0.1-999	10
F-06	Cycle work times (among them----=numerous times) Unit: times	0-9999 or countless times	1
F-07	Forward rotation in place delay Unit: second accuracy ± 0.2 second	0.0-999.9	0.0
F-08	Reverse in place delay Unit: second accuracy ± 0.2 second	0.0-999.9	0.0
F-09	Number of pulses per revolution: 1-9999 (X10) Unit: 10 (for example, the step angle is 1.8 degrees, the stepping motor drives 8 segments, and one revolution is $360 / 1.8 * 8 = 1600$, setting 160, actual 1600)	1-9999	160
F-10	Main interface display content Up: motor coil speed (unit: RPM) Downlink: delay time (unit: s) / number of cycles (unit: Times) 00- Motor coil speed delay time 01- Motor coil speed cycle times	0-1	00
F-11	Action when pressing pause key0 - slow stop of motor deceleration1 - motor stops immediately (emergency stop has impact)	0-1	0
F-12	Acceleration and deceleration level 1-100, 1 slowest, 100 fastest	1-100	20
F-13	Postal address	1-255	1

【F01 : action process mode selection】 list of required action processes

number	Action description
【F01】→P01	The motor works with [knob on controller].
【F01】→P02	It keeps rotating after pressing the button, and stops when it is released. [Press CW] Always rotate forward [Press CCW] Always reverse
【F01】→P03	After pressing the button, keep rotating, Press STOP to stop. [press CW] forward rotation [press CCW] reverse rotation
【F01】→P04	After pressing the button, it can rotate forward or reverse-delay according to the set distance, and it can cycle F-06 times. [Press CW] Forward rotation-Delay (F-07) [Press CCW] Reverse rotation-Delay (F-08)
【F01】→P05	After pressing the button, it can cycle according to the set distance forward or reverse delay(F-06). Return to zero at the end of the cycle. [press CW] forward rotation delay (F-07), Cycle (F-06), return to zero [press CCW] reverse delay (F-08),Cycle (F-06), return to zero.
【F01】→P06	After pressing the button, cycle forward and reverse according to the set distance. Abbreviations: [press CW] forward delay (F-07) - reverse delay (F-08), [press CCW] reverse delay (F-08) - forward delay (F-07), above cycle (F-06)
【F01】→P07	After pressing the button, the motor will rotate forward or reverse permanently, release the button, - delay - return to zero. Abbreviations: [press CW] forward rotation - release - delay (F-07) - return to zero, [press CCW] reverse rotation - release - delay (F-08) - return to zero.
【F01】→P08	After pressing the button, forward or reverse - delay according to the set time.

	Recyclable (F-06). Abbreviations: [press CW] forward rotation time (F-07) - delay (F-08), [press CCW] reverse rotation time (F-08) - delay (F-07), the above cycle (F-06).
【F01】→P09	After power on, it will automatically cycle forward and reverse according to the set distance. Abbreviations: forward delay (F-07) - reverse delay (F-08), cycle (F-06)

7. Product size



SMC01 stepper motor controller communication protocol

V1.0

1. Protocol Introduction

Using TTL serial transmission interface and MODBUS-RTU communication protocol, this product only supports function codes 0x03, 0x06, and 0x10.

2. Introduction to Communication Protocol

Information transmission is asynchronous in Modbus-RTU mode

Starting bit	1 bit
Data bits	8 bit
Parity bit	not have
Stop bit	1 bit

Data frame structure

Data frame interval	Address code	function code	data area	CRC check
3.5 bytes or more	1 byte	1 byte	N byte	2 byte

Before sending data, it is required that the data bus rest time, i.e. no data transmission time, be greater than 3.5 (e.g. 5ms at a baud rate of 9600). Message transmission must start with a pause interval of at least 3.5 bytes, and the entire message frame must be treated as a continuous data transmission stream. If there is a pause time of more than 3.5 bytes before the frame is completed, The receiving device will refresh incomplete messages and assume that the next byte is the address field of a new message. Similarly, if a new message starts with the previous message within less than 3.5 characters, the receiving device will consider it a continuation of the previous message.

1.1 Address Code

The address code is the first byte (8 bits) of each communication information frame, ranging from 1 to 255 (initially set to 1, 0 and also the broadcast address). This byte indicates that the slave set by the user will receive information sent by the host. Each slave must have a unique address code, and only slaves that match the address code can respond to feedback messages. When the slave sends back information, the returned data starts with their respective address codes. The address code sent by the host indicates the slave address to be sent, while the address code returned by the slave indicates the slave address to be returned. The corresponding address code indicates where the information comes from.

1.2 Function Code

The function code is the second byte transmitted in each communication information frame, and the ModBus communication protocol can define function codes ranging from 1 to 127. Sent as a host request, telling the slave what action to take through a function code. As a response from the slave, the function code returned by the slave is the same as the function code sent from the master, and indicates that the slave has responded to the master and performed

relevant operations. This machine only supports function codes 0x03, 0x06, and 0x10.

Function code	Definition	Operation (binary)
0x03	Read register data	Read data from one or more registers
0x06	Preset Single Register	Write a set of binary data into a single register
0x10	Write multiple registers	Write multiple sets of binary data into multiple registers

1.3 Register

Introduction to Protocol Registers (Data within a Single Register Address is Double Byte Data)

Name	Illustrate	Byte count	Reading and writing	Register address
System parameters, written will be stored				
F-01	Action process mode selection	2	R/W	0000H
F-02	Number of forward pulses	4	R/W	0001H
F-03	Forward rotation speed	2	R/W	0003H
F-04	Reverse pulse count	4	R/W	0004H
F-05	Reverse speed	2	R/W	0006H
F-06	Number of working cycles	2	R/W	0007H
F-07	Forward to position delay	2	R/W	0008H
F-08	Reverse in place delay	2	R/W	0009H
F-09	Number of pulses per revolution	2	R/W	000AH
F-10	Main interface display content	2	R/W	000BH
F-11	Action when pressing the pause button	2	R/W	000CH
F-12	Acceleration and deceleration levels	2	R/W	000DH
F-13	Module address 1-255	2	R/W	000EH
COM	Control command 0 using serial port instead of 1 using serial port control	2	R/W	000FH
Read information and run information				
	Current motor operating status: 00- stop 01- acceleration status 02- deceleration status 03- constant speed status	2	R	0010H
	Current motor rotation direction: 00- forward rotation 01- reverse rotation	2	R	0011H
Serial Port Control Run Command (Set COM (000F) address to 1 serial port control mode before serial port control)				
Serial Port Control Run Command	Serial port control operation mode 00- forward rotation 01- reverse rotation 02- slow stop 03- immediate stop 0xFF - default state after execution	2	R/W	0100H

	Serial port control for running, 00- no permanent rotation 01- enable permanent rotation default 0	2	R/W	0101H
	The distance of the serial port control operation is 16 bits higher than the pulse count (which works under permanent rotation), with a default of 10000 bits	2	R/W	0102H
	The distance of the serial port control operation is 16 bits lower than the pulse count (which works under permanent rotation), with a default of 10000 bits	2	R/W	0103H
	The acceleration and deceleration levels controlled by serial port are 1-100, with a default of 20	2	R/W	0104H
	The default running speed for serial port control is 100	2	R/W	0105H

Example 1: Reading System Parameters (F-01 to F-02)

Using the [03 (0x03) Read Holding Register] instruction

Host sending:

01	03	00 00	00 02	C4 0B
Slave address	Function code (Read Register)	Starting address The regulation is 2 bytes	Number of Registers	CRC Check Code

The controller responds:

01	03	04	00 01 06 40	A9 A3
Slave address	Function code (Read Register)	Number of Registers x2	Register value Quantity=Number of registers x2	CRC Check Code

Example 2: Serial port controller operation

1) Set the controller to serial port control mode

Host sending:

01	06	00 0D	00 01	D9 C9
Slave address	Function code	Starting address The regulation is 2 bytes	Write value Quantity: 2 bytes	CRC Check Code

The controller responds:

01	06	00 0D	00 01	D9 C9
Slave address	Function code	Starting address The regulation is 2 bytes	Write value Quantity: 2 bytes	CRC Check Code

2) Modifying parameters for serial port control operation

Host sending:

01	10	01 02	00 02	04	00 00 4E 20	4B 9E
Slave address	Function code	Starting address The regulation is 2 bytes	Number of registers	Byte count	Write value Quantity:=Bytes	CRC Check Code

The controller responds:

01	10	01 02	00 02	E1 F4
Slave address	Function code	Starting address The regulation is 2 bytes	Number of registers	CRC Check Code

3) Serial port control forward conversion

Host sending:

01	06	01 00	00 00	88 36
Slave address	Function code	Starting address The regulation is 2 bytes	Write value Quantity:=Bytes	CRC Check Code

The controller responds:

01	06	01 00	00 00	88 36
Slave address	Function code	Starting address The regulation is 2 bytes	Write value Quantity:=Bytes	CRC Check Code

Serial port control operation command (set 000F to 1 serial port control mode before serial port control)				
Serial Port Control Run Command	Control method 0 Manual control 1 Remote control from upper computer	2	R/W	000FH
	Serial port reading operation status 00- forward rotation 01- reverse rotation 03- stop immediately	2	R/W	0100H
	The number of pulses for serial port control operation is 16 bits high, with a default of 10000 bits	2	R/W	0101H
	The default number of pulses for serial port control operation is 10000 if the low 16 bits are used	2	R/W	0102H

	The acceleration and deceleration levels controlled by serial port are 1-100, with a default of 20	2	R/W	0103H
	The default running speed for serial port control is 100	2	R/W	0104H

1. Set the remote control mode of the upper computer (default address 01)

01 06 00 0F 00 01 48 0A

2. Set forward, reverse, and stop

01 10 01 01 00 00 00 27 10 01 64 CRCH CRCL